

The QMount has been designed for use in a Home, Gym, Office, and Dorms. The following instructions explain how to mount the QMount directly to drywall.

### Tools Required

Pencil  
Phillips screwdriver  
Drill with 1/16" drill bit

### Parts Included

1 or 2 Rails\* (includes 6 Multi-Purpose Construction Screws)  
1 Qmount holder  
1 Rubber spacer for use with Theragun PRO Massage Gun

### Step 1

Locate stud behind drywall.

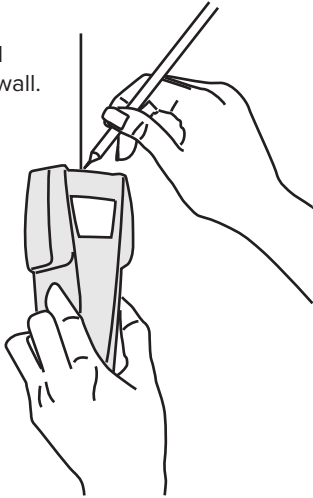

### Step 2

Use the Rail to mark the hole locations at a suitable height.

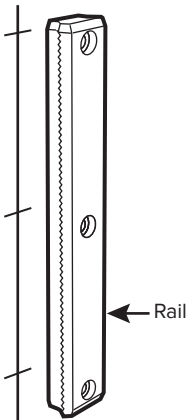

### Step 3

Mount the rails using the 6 included Multi-Purpose Screws

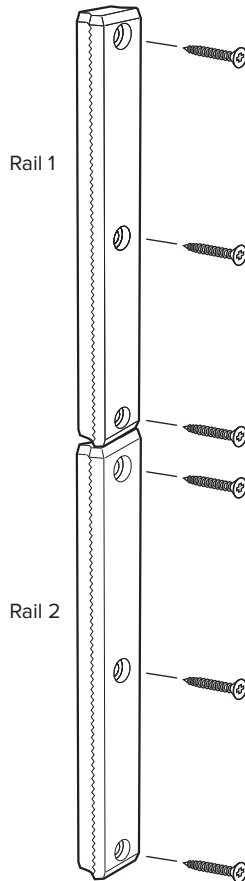

\*Your order may include 1 or 2 rails.

### Important

The **Cam Lever** is preset at the factory so the **Holder** will be snug on the rail when the **Cam Lever** is in the locked position.

**DO NOT ROTATE** the **Cam Lever** Clockwise or Counterclockwise at anytime. The **Cam Lever** should only be flipped up or down as shown below.

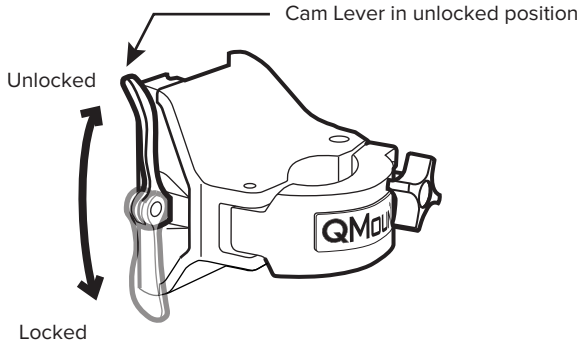

### Step 4

With **Cam Lever** in full unlock position, slide the **Qmount Holder** to desired position on the rail.

Move Cam Lever straight down to the locked position.

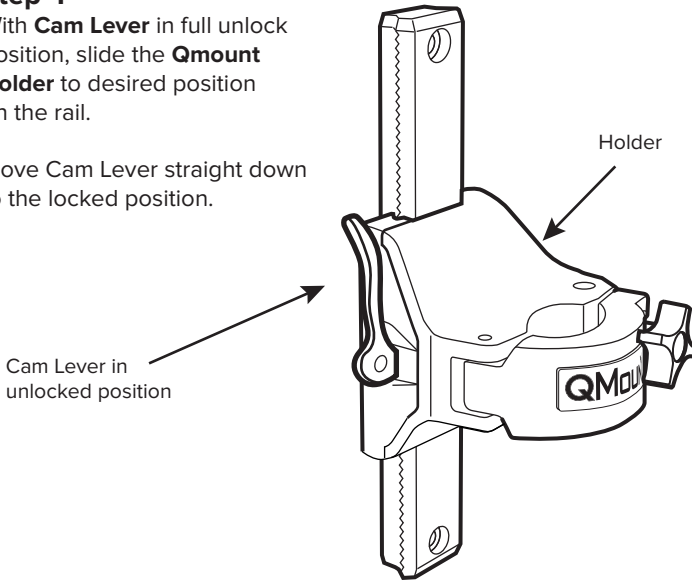

### Step 5

Place your massage gun in the **Holder**. Lock in place using the **Four-Arm Knob**.

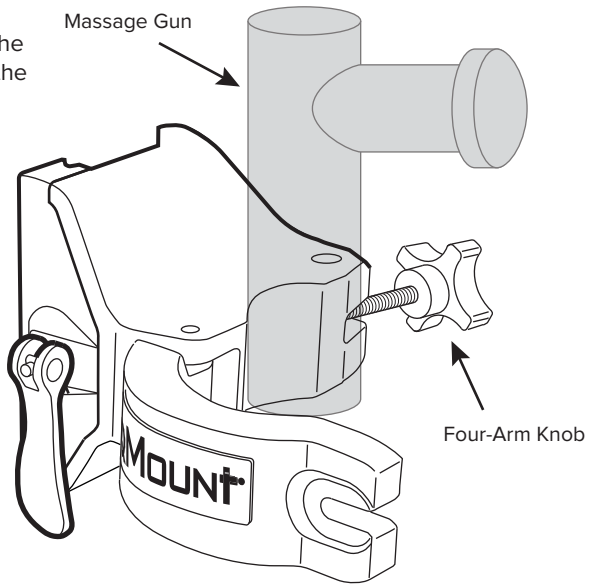

### Step 6

Adjust the **Qmount** to any position on the rail, lock in place with the **Cam Lever**, and enjoy a hands-free massage.

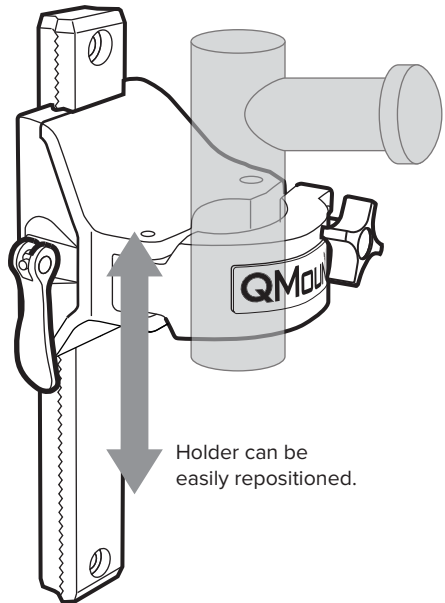

# Installation Guide for Rubber Spacer

Note: Some massage guns (including the Theragun PRO and Theragun Elite) have smaller diameter handles. To accommodate these types of massage guns, you will need to add the rubber spacer (included). Follow the steps below to add the rubber spacer.

## Step 1

Be sure the area where the **Rubber Spacer** will be applied is clean and dry.

Peel the backing from the **Rubber Spacer** and apply onto **Holder** as shown.

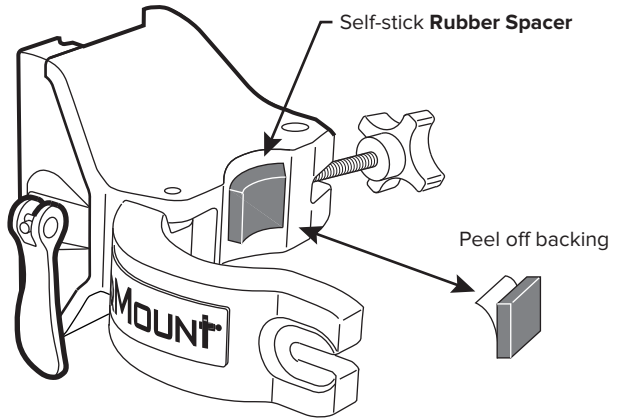

## Step 2

Place massage gun in **Holder** and lock in place using the **Four-Arm Knob**.

